

**LI-ION**  
TECHNOLOGY

INNOVATIVE LITHIUM-ION



# X Series Electric Forklift Truck

with capacities of 4,000 to 5,000kg

*The World of Hangcha*  
SINCE 1956





8

HANGCHA

50

Li-ION BATTERY

HANGCHA

## Exterior

- / A new exterior design method is used to form a stylish and elegant exterior with streamlined curved surfaces and smooth ethereal lines.
- / The vehicle is compact, simple and sturdy in appearance.
- / A fully enclosed console space.
- / Fully open side door.

## Stability

- / The drive motor is arranged in parallel, the battery is placed at the bottom of the vehicle frame, the wheelbase and rear wheel pitch are increased, the swing point of the steering axle is raised, and the distance between the front of the fork and the front axle is reduced, to enable excellent stability.

## Comfort

- / In accordance with the ergonomically design, the wheelbase is increased to enable enlarged leg space. The radius of the hand wheel is reduced to 300mm and the seat can be adjusted backwards and forwards, so that the operator can choose the best driving position.
- / The dashboard, tilt cylinder and flat bottom panel are designed to be fully enclosed to enable more comfortable and safer operations.
- / The multifunctional color-screen instruments have clear human-computer interfaces displaying clear readings.
- / Personalized design: increased storage space, USB port, etc.

## Safety

- / The optimized design of the wide-view mast, wide-view overhead guard and low dashboard enables a broader view of the operator and higher safety.
- / The LED headlights and combination lights enable the operator to have a good view in various circumstances.
- / The all-round vision rearview mirror provides a broader rear view and higher driving safety.
- / The intelligent sensing enables buffered descending. When the fork is 100 - 60mm away from the ground, the descending will automatically slow down, so that the goods and pallet will not hit the ground and the goods and ground can be protected effectively.
- / The electronic and hydraulic overload protection devices comply with safety regulations.
- / An optional OPS safety system is provided.



## High speed, high efficiency

- / With increased turning angle and small turning radii of the inner and outer steering wheels, the vehicle can operate in narrow aisles.
- / With several speed gears, the vehicle is adapted to different operating environments.
- / With a high-power driving motor and a high speed ratio gearbox, a large-tonnage 5t vehicle, for example, can have its maximum driving speed increased to 16.5km/h and maximum full-load upslope degree increased by up to 15%.
- / A high-power oil pump motor and a large-displacement silent pump are used to significantly improve the lifting speed. A large-tonnage 5t vehicle, for example, can have its maximum full-load lifting speed increased to 310mm/s.
- / With reduced distance between the front of the fork and the front axle and other new stability-enhancing technologies, the load capacity of the attachments and high-lift mast of the forklift is significantly improved.
- / A new compact design concept is adopted to reduce the width of the vehicle.
- / Light weight and low driving power consumption. The brake kinetic energy regeneration system effectively saves on electric power and improves the use time after a single charge.



## Advancement

- / The high-frequency MOSFET integrated controller ensures smooth and accurate driving and lifting control, and has excellent speed regulation performance, good performance of electronic control matching the motor, functions of regenerative braking, reverse braking and anti-sliding on ramps, etc., and high safety and reliability.
- / The branded multifunctional color-screen instruments have the functions of battery display, timer and fault diagnosis and can accurately display information under harsh environments.
- / The branded AC controller enables the forklift's driving, steering, lifting, tilting and other actions to be controlled by a computer.
- / Regenerative braking (when stopping, slowing down, reversing or driving down a ramp, etc., being energy-saving and efficient, the forklift can have its drive motor working as a power generator to charge the battery through the controller.)
- / The main electrical components such as the motor controller, contactor, power plug and emergency cut-off switch are all branded high-quality products.

## Maintainability

- / The fully opened hood quite facilitates the maintenance of the battery, oil pump motor and electric control assembly.
- / The foot panel can be dismantled without a tool and facilitates the overhaul and maintenance of the driving motor and various systems.
- / The brake fluid can be added after the shroud cap and the oil tank cap are opened.
- / An optional laterally-dismounted battery is provided to enable quick replacement of the battery.

## Battery Specification

Battery	Capacity (Ah/5h)	4t	4.5t	mini5t	5t
Lead-acid	600	●			
	700	○	●	●	●
	775	○	○	○	○
Lithium	542	●	●	●	●
	604	○	○	○	○

Note: ● Battery Std; ○ Battery Opt;

## Options

- / Super-elastic solid tire
- / Seamless solid tire
- / Triple and quadruple multiway valves
- / Alarm light
- / Rear LED operation light
- / Blue light
- / Rear reversing armrest horn button
- / Large-capacity battery
- / PVC ceiling
- / Battery charger
- / Chair sensing system
- / Electro-hydraulic proportional valve, thumb switch
- / Video monitoring system
- / Fully-suspended seat
- / Fully enclosed cab
- / Left and right rear view mirrors
- / Free duplex mast
- / Free triplex mast
- / Built-in side shift fork
- / Forks of other lengths
- / Widened fork carriage
- / Other attachments
- / Battery removed sideways

## Standard specification

- / AC electric control motor
- / Emergency power off switch
- / Multifunctional color-screen instruments
- / Pneumatic tire
- / Mechanical handbrake
- / Two-way multi-way valve
- / Rubber pedal pads of all sizes
- / 3 m duplex wide-field-of-view mast
- / Vehicle LED lights
- / Panoramic rear view mirror
- / Fully hydraulic power steering
- / Angle-adjustable steering column
- / Horn, reversing buzzer
- / Tool box, folder
- / Silent gear pump
- / Intelligent descending buffering device
- / Traction pin



## Mast Specification

Type	Max. fork height	Lowered	Overall height		Free lift		Tilt range		Capacity		
			With backrest	Without backrest	With backrest	Without backrest	F	R	load capacity at 600mm		
									Single tire		
	mm	mm	mm	mm	mm	mm	(°)	(°)	5t		
									kg		
STD Duplex	2700	2250	3870	3620	150	150	5	10	5000		
	3000	2350	4170	3870	150	150	5	10	5000		
	3300	2500	4470	4170	150	150	5	10	5000		
	3700	2825	4870	4675	150	150	5	10	5000		
	4000	2975	5170	4975	150	150	5	6	5000		
	4500	3300	5670	5550	150	150	5	6	5000		
	5000	3550	6170	6050	150	150	5	6	5000		
	5500	3800	6670	6550	150	150	5	6	4950		
	6000	4050	7170	7050	150	150	5	6	4600		
Full Free Lift	2800	2250	3970	3550	1080	1500	5	10	5000		
	3000	2350	4170	3850	1180	1500	5	10	5000		
	3300	2500	4470	4150	1330	1650	5	10	5000		
	3700	2600	4870	4450	1430	1850	5	10	5000		
	4000	2825	5170	4825	1655	2000	5	10	5000		
	4050	2180	5220	4840	1010	1430	5	6	5000		
Triplex	4300	2250	5470	5050	1080	1500	5	6	5000		
	4500	2315	5670	5245	1145	1570	5	6	5000		
	4700	2415	5870	5545	1245	1570	5	6	4970		
	5000	2500	6170	5800	1330	1700	5	6	4890		
	5500	2850	6670	6550	1680	1800	5	6	4750		
	6000	3125	7170	7125	1955	2000	5	6	4610		
	6500	3325	7670	7625	2155	2200	3	6	3850		
	7000	3450	8170	8150	2280	2300	3	6	3600		

## Mast Specification

Type	Max. fork height	Lowered	Overall height		Free lift		Tilt range		Capacity		
			With backrest	Without backrest	With backrest	Without backrest	F	R	load capacity at 500mm		
									Single tire		
	mm	mm	mm	mm	mm	mm	(°)	(°)	4t	4.5t	5t
									kg	kg	kg
STD Duplex	2800	2150	3970	3590	150	150	5	10	4000	4500	4990
	3000	2250	4170	3790	150	150	5	10	4000	4500	4990
	3300	2400	4470	4090	150	150	5	10	4000	4500	4990
	3700	2600	4870	4490	150	150	5	10	4000	4500	4990
	4000	2825	5170	4825	150	150	5	10	4000	4500	4990
	4500	3075	5670	5325	150	150	5	6	4000	4500	4990
	5000	3400	6170	5900	150	150	5	6	4000	4500	4990
	5500	3650	6670	6400	150	150	5	6	3950	4450	4950
	6000	4050	7170	6900	150	150	5	6	3700	4200	4600
Full Free Lift	2650	2075	3820	3400	905	1330	5	10	4000	4500	4990
	3000	2250	4170	3750	1080	1500	5	10	4000	4500	4990
	3300	2400	4470	4050	1230	1650	5	10	4000	4500	4990
	3700	2600	4870	4450	1430	1800	5	10	4000	4500	4990
	4000	2825	5170	4825	1655	2000	5	10	4000	4500	4990
Triplex	4250	2180	5420	5040	1010	1430	5	6	4000	4500	4990
	4500	2250	5670	5250	1080	1500	5	6	4000	4500	4990
	4700	2315	5870	5445	1145	1570	5	6	4000	4500	4990
	5000	2450	6170	5850	1280	1600	5	6	4000	4470	4850
	5500	2600	6670	6300	1430	1800	5	6	3850	4340	4800
	6000	2825	7170	6825	1655	2000	5	6	3710	4210	4650
	6500	3075	7670	7375	1905	2200	3	6	3400	3650	4300
	7000	3300	8170	8000	2130	2300	3	6	2800	3000	3600

Note: With load backrest; Height of standard load backrest is 1092 mm.





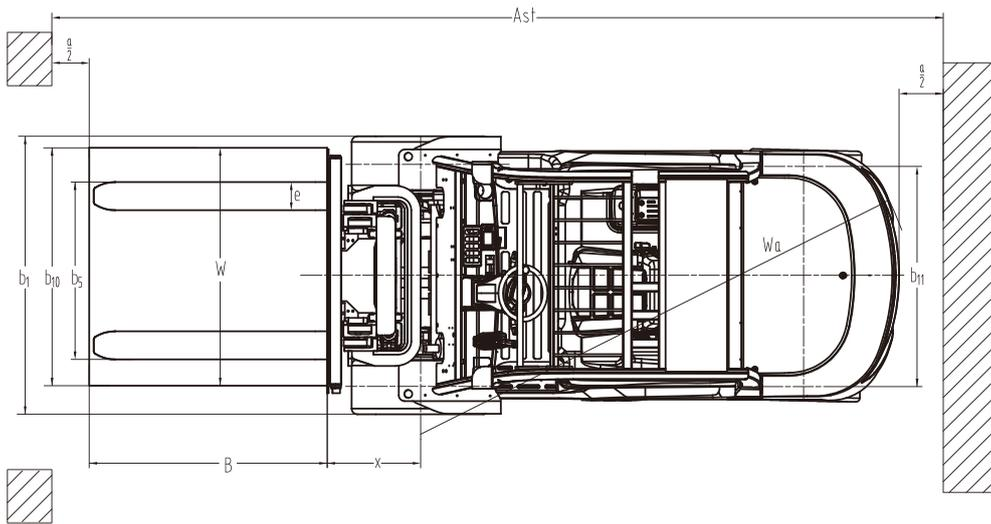
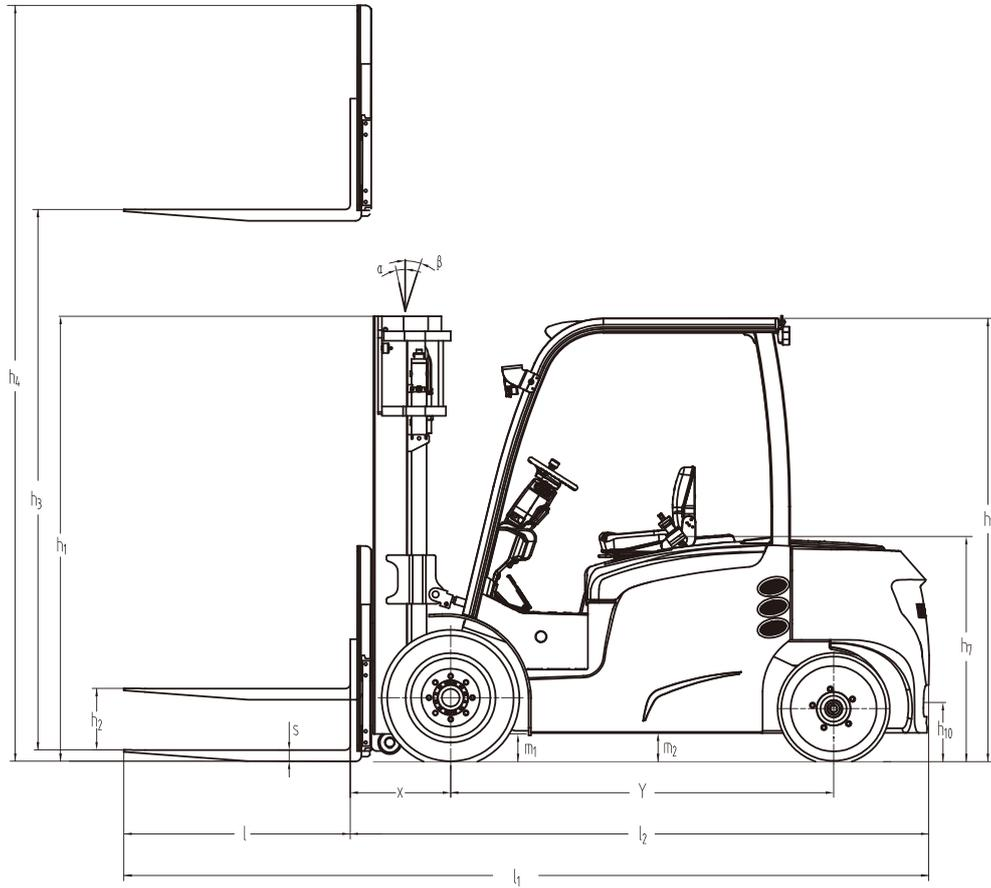

$A_{st}=B+x+W+a$      $B$ : Length of load or forks which is longer     $a=200\text{mm}$  safety clearance

**RATED CAPACITY AND LOAD DIAGRAM**

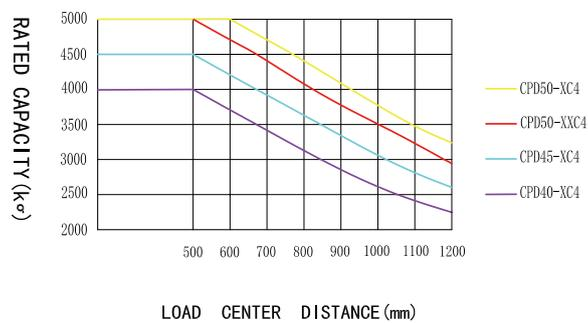





HANGCHA

50

Li-ION

HANGCHA

HANGCHA



**HANGCHA FORKLIFT CANADA INC.**

**Company address:**

6-980 Rue Valois, Vaudreuil-Dorion,  
QC, J7V 8P2, Canada

Toll Free: 877-319-HCFC (4232)

Landline: 450-319-HCFC

[info@hcforkliftcanada.com](mailto:info@hcforkliftcanada.com)

[www.hcforkliftcanada.com](http://www.hcforkliftcanada.com)



ISO14001:2015



ISO9001:2015



Follow us on  
Facebook



Follow us on  
YouTube



Follow us on  
WeChat



Download "Hangcha  
Forklift" App

HANGCHA GROUP CO., LTD. reserves the right to make any changes without notice concerning colors, equipment, or specifications detailed in this brochure, or to discontinue individual models. The colors of trucks, delivered may differ slightly from those in brochures.