

A Series Pallet Truck With High Lift Specification

Distinguishing marks	1.1	Manufacturer	HANGCHA GROUP CO.,LTD.	
	1.2	Manufacturer's type designation	CBD20-AC1-L	
	1.3	Drive:electric(battery or mains),diesel,petrol,fuel gas	electric	
	1.4	Operator type:hand,pedestrian,standing,seated,order-picker	pedestrian	
	1.5	Load capacity/rated load	Q (kg/lb)	2000/4000
		Load capacity mast lift	Q (kg/lb)	800/1800
		Load capacity support arm lift	Q (kg/lb)	2000/4000
	1.6	Load centre distance	c(mm/in)	600/24
	1.8	Load distance, centre of drive axle to fork	x(mm/in)	840 ³¹ /33 ³¹
1.9	Wheelbase	y(mm/in)	1409 ³¹ /55.5 ³¹	
Weights	2.1	Service Weight without battery	kg/lb	536/1200
Wheels, Chassis	3.1	Tyres:solid rubber,superelectric,pneumatic,polyurethane	PU	
	3.2	Tyre size, front	mm/in	φ230×75
	3.3	Tyre size, rear	mm/in	φ80×70
	3.4	Additional wheels (dimensions)	mm/in	φ100×40
	3.5	Wheels, number front / rear (x = driven wheels)		1×2/4
	3.6	Tread, front	b ₁₀ (mm/in)	480/18.9
	3.7	Tread, rear	b ₁₁ (mm/in)	375/14.8
Dimensions	4.4	Lift	h ₃ (mm/in)	550/21.7
	4.5	Initial lift	h ₅ (mm/in)	125/4.9
	4.9	Height of tiller in drive position min./max.	h ₁₄ (mm/in)	960/1320 (37.8/52)
	4.15	Height, lowered	h ₁₃ (mm/in)	90/3.5
	4.19	Overall length	l ₁ (mm/in)	1899/74.8
	4.20	Length to face of forks	l ₂ (mm/in)	749/29.5
	4.21	Overall width	b ₁ (mm/in)	750/29.5
	4.22	Fork dimensions	s/e/l (mm/in)	60/185/1150 (2.4/7.3/45.3)
	4.25	Distance between fork-arms	bs (mm/in)	560/22
	4.32	Ground clearance, centre of wheelbase	m ₂ (mm/in)	25/0.98
	4.33	Aisle width for pallets 1000 x 1200 crossways	Ast (mm/in)	2442 ³¹ /96.1 ³¹
4.34	Aisle width for pallets 800 x 1200 lengthways	Ast (mm/in)	2360 ³¹ /92.9 ³¹	
4.35	Turning radius	Wa (mm/in)	1620 ³¹ /63.8 ³¹	
Performance data	5.1	Travel speed, laden/unladen	kph (mph)	6.0/6.0 (3.7/3.7)
	5.2	Lift speed, laden/unladen	m/s (ft/min)	0.120/0.170 (23.62/33.46)
	5.3	Lowering speed, laden/unladen	m/s (ft/min)	0.150/0.130 (29.53/25.6)
	5.8	Max.gradeability, laden/unladen	%	8/20
	5.10	service brake		Electromagnetic braking
Electric motor	6.1	Drive motor rating S2 60 min.	kw/hp	1.5/2.0
	6.2	Lift motor rating at 53 5%	kw/hp	2.2/2.95
	6.3	Battery acc. to DIN 43531/35/36 A, B, C, no		3P2B210
	6.4	Battery voltage/nominal capacity K5	V/Ah	24/210
	6.5	Battery weight	kg/lb	194/428
Others	8.1	Type of drive control		AC SpeedControl
	8.4	sound pressure level at the driver's seat	dB(A)	70

Note:1)Load section raised / lowered: + 64mm(2.5in)

Specifications are subject to change without notice.

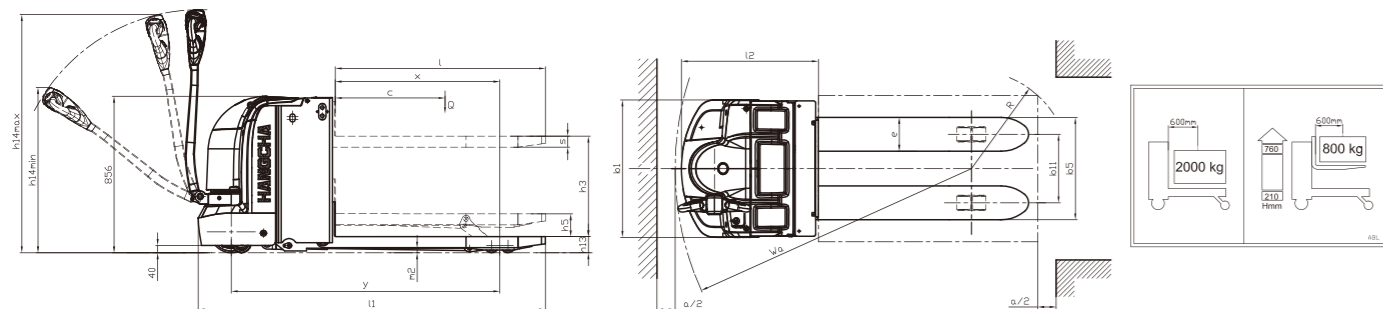

HANGCHA FORKLIFT CANADA INC.

Company address:
6-980 Rue Valois, Vaudreuil-Dorion,
QC, J7V 8P2, Canada

Toll Free: 877-319-HCFC (4232)
Landline: 450-319-HCFC

info@hcforkliftcanada.com
www.hcforkliftcanada.com



Follow us on Facebook



Follow us on YouTube



Follow us on WeChat

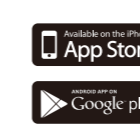

Download "Hangcha Forklift" App

2020 VERSION 1/COPYRIGHT 2020/12

HANGCHA GROUP CO., LTD. reserves the right to make any changes without notice concerning colors, equipment, or specifications detailed in this brochure, or to discontinue individual models. The colors of trucks, delivered may differ slightly from those in brochures.



A Series Pallet Truck With High Lift

with capacities of 2,000kg



The World of Hangcha

A Series Pallet Truck With High Lift

The A series pallet with high lift is a pedestrian pallet truck which can also be used for order picking and light stacking operations. In addition to the support arm lift the load can be raised to an overall height of 675 mm via a simplex mast contained in the battery compartment. This height adjustment is really appreciated when order picking, restocking shelves in retail stores or assembly line activities in manufacturing industries.

**Power/
Manoeuvrable/
Compact**



Stability

- / Integrated mast matched to chassis width.
- / High resistance fork carriage and load arms made of robust pressed steel.

Performance

- / The arms have high lifting function, and there is better trafficability.
- / With the design of handling by the double pallets (upper and lower pallets), it cannot only meet the light stacking work demand, but also can improve the material handling efficiency.
- / The powerful lift & AC traction motors supply the performance needed to achieve a high level of productivity.
- / With the latest CURTIS control system, control is precise and stable, efficiency is higher.
- / With CANBUS bus structure, the communication of the truck is faster and reliable.
- / The truck has the regenerative braking, and has anti-sliding protection at the ramp.

Comfort

- / All commands integrated to the tiller, the function buttons can be operated in comfortable way.
- / For safe use in confined areas, tiller operates in vertical position via crawl speed button.
- / Additional buttons located on the truck side allows the operator for example to pick goods at a comfortable height.
- / Long tiller arm reduces steering effort to maximise manoeuvrability.

Maintenance

- / No carbon brushes – maintenance-free traction motor.
- / Extensive instrument display allow the operator to monitor the situation at a glance.
- / Easy access to all parts with one-piece back panel, maintenance is very convenient.

Reliability

- / With five-supporting-point and low gravity center design, a rugged construction makes the pallet truck that can be relied on.
- / With the non-contact proximity switch, such switch has long service life and can operate reliably.
- / The lifting electric limit switch is provided, the hydraulic power unit will not have overflow. It is more energy-saving, and the power unit motor can also be protected.
- / The sturdy mast and the durable carriage are made of high-grade rolled steel contributing to a long truck life as well as fast, easy and safe load handling.
- / The stamped and formed forks have higher strength and shock resistance.

Safety

- / The release braking, reverse braking and emergency braking to ensure the truck running safety.
- / No roll-back when starting on a slope.
- / The truck has the lowering intelligent protection function. When the forks are less than 150mm away from the ground, the side lowering button is ineffective.
- / With the emergency reverse button at the head of the handle, when the truck runs back and there is emergency, it can effectively prevent the driver from injury.

Standard specification

- / AC traction motor
- / CURTIS controller
- / Additional buttons for lifting/lowering the forks on chassis side
- / Multi-functional instrument
- / Polyurethane dual load wheels
- / Fork length: 1150mm
- / Distance between fork-arms: 560mm
- / Initial lifting: 125mm
- / CAN bus multi-functional handle
- / Lifting electric limit
- / Horn
- / Key switch
- / Crawl speed function
- / Upright-tiller creep speed running
- / Auto reverse safety switch

Options

- / Load backrest
- / Automatic picking function
- / Password lock
- / Cold storage



The truck benefits from a long tiller with a low mounting point ensuring a large safety clearance between operator & chassis



Automatic picking functions (OPT) enable all kind of loads to be lifted or lower quickly and without fatigue



Easy battery charging - suitable for any convenient electric outlet



The support arm lift capacity is 2000 kg while the mast lift capacity is 800 kg