

## Articulating Booms

		HANGCHA GROUP CO.,LTD.		
		GTHZ120	GTHZ170	GTHZ170C
1	Manufacturer			
2	Model			
3	Working height	m	11.95	16.95
4	Platform height	m	9.95	14.95
5	Horizontal height	m	7.00	9.43
6	Up and over height	m	4.77	7.16
7	Length	m	5.48	6.84
8	Length (storage)	m	3.74	5.4
9	Wheel base	m	1.65	2
10	Width	m	1.22	1.75
11	Height	m	1.99	2.09
12	Height (storage)	m	2.16	2.09
13	Basket size	m	1.20x0.77	1.20x0.77
14	Turning radius inside	m	1.55	2.0
15	Turning radius outside	m	3.25	4.30
16	Turning radius outside (basket)	m	3.34	5.6
17	Ground Clearance	m	0.10	0.15
18	Capacity	kg	200	200
19	Jib movement		±70°	±70°
20	Basket rotation		140°	140°
21	Turret rotation		350°	355°
22	Drive speed	km/h	6.00	4.50
23	Working speed	km/h	0.60	0.60
24	Gradeability	%	25%	22%
25	Maxi slope acceptable	%	3° or 5%	3° or 5%
26	Tires	m	0.60x0.19	0.60x0.19
27	Wheel steer		2	2
28	Wheel drive		2	2
29	Batteries (C5)	V/Ah	300Ah,2x24V	300Ah,2x24V
30	Weight	kg	6550	7030

### Size Range

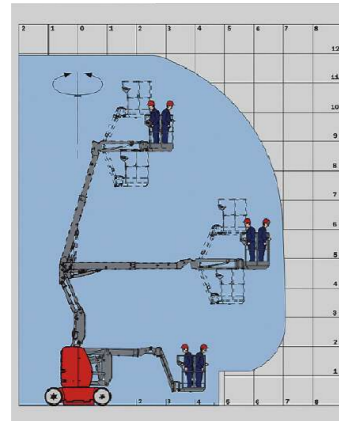
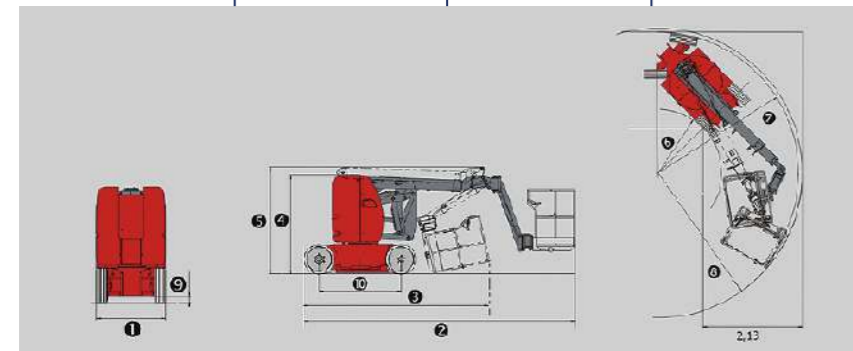

GTHZ120

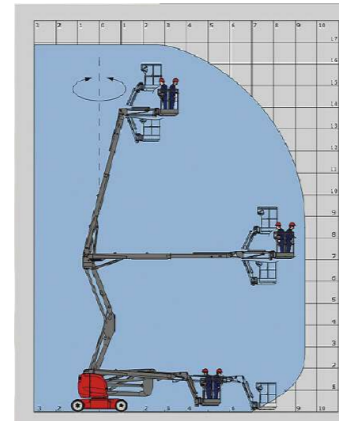

GTHZ170



### HANGCHA FORKLIFT CANADA INC.

**Company address:**  
6-980 Rue Valois, Vaudreuil-Dorion,  
QC, J7V 8P2, Canada

Toll Free: 877-319-HCFC (4232)  
Landline: 450-319-HCFC

canada@hcforklift.com  
www.hcforkliftcanada.com



Follow us on Facebook



Follow us on YouTube



Follow us on WeChat



Download "Hangcha Forklift" App

2020 VERSION 1/COPYRIGHT 2020/12

HANGCHA GROUP CO., LTD. reserves the right to make any changes without notice concerning colors, equipment, or specifications detailed in this brochure, or to discontinue individual models. The colors of trucks, delivered may differ slightly from those in brochures.



## Articulating Booms

GTHZ120 / GTHZ170 / GTHZ170C

*The World of Hangcha*  
SINCE 1956





## Articulating Booms

This machine has articulation boom which can work across the obstacle. It can carry two people and some tools in the basket. The machine allows you to operate it in limited place with narrow design and small radius turning system. You can operate the machine from basket or base control, so when you want to move it, you do not need to go down the machine. Multi-motion control allows you to operate several actions simultaneously. With this machine, you can do work more efficient and comfortable.

Easy/  
Efficiency/  
Economy



### Features

- / Increase the ground clearance to improve passability;
- / This platform is provided with rough terrain tires, which are more suitable for working outside;
- / The driving speed is 6.1km/h.
- / Climbing performance is increased to 30%;
- / Integrated design of motor and reducer. The motor controls the reducer to brake, reducing the impact of braking and improving the user's comfort.
- / Potentiometer is installed on the equipment, so that the left and right wheels have different speed when steering, so the steering is more stable.
- / The drive motor is AC motor.



GTHZ170C

GTHZ170

GTHZ120

### Standard specification

- / Electrical battery traction
- / Negative brakes
- / Lifting brakes
- / Hour meter
- / Warning buzzer in the basket
- / 220V predisposal
- / Voltage indicator
- / Safety manual pump
- / Bus CAN technology
- / Diagnostic help integrated
- / Dual electrical motors
- / No marking tires
- / Anti-roll system
- / Integrated charger

### Options

- / Working lights
- / Flashing light(all motion alarm)
- / Buzzer
- / Air predisposal
- / Electrical plug 220V
- / Over-load sensor system

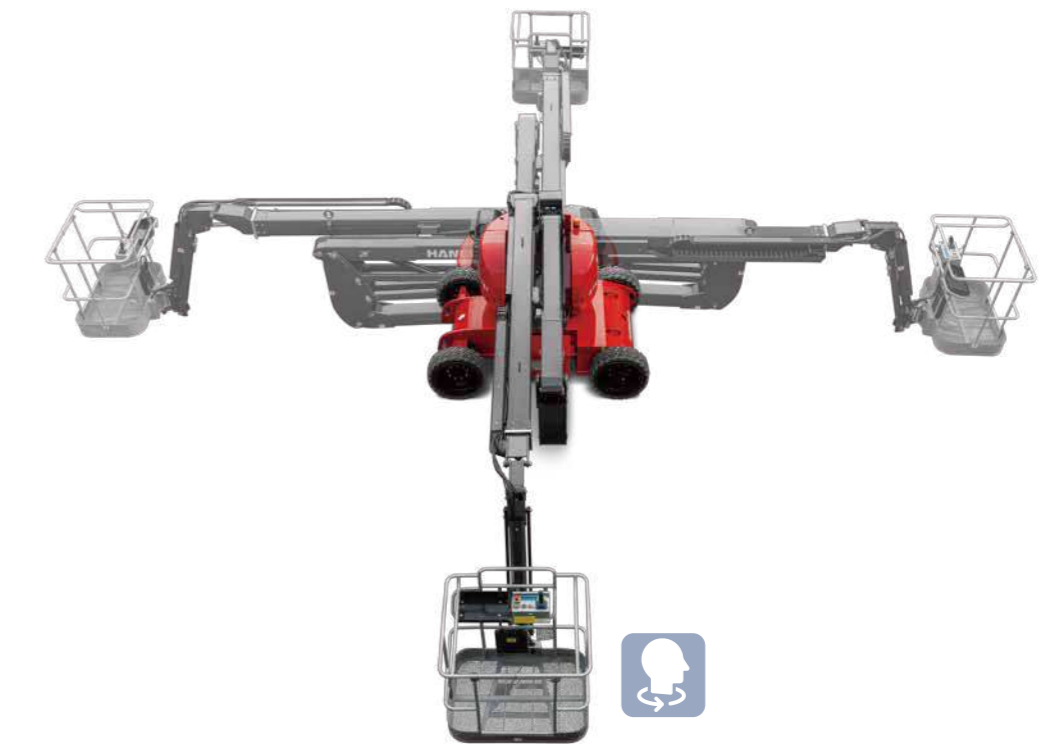

Basket: can be rotated left and right at an Angle of 140°

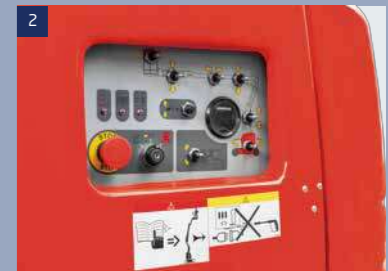

Base control box: the control box can be used to control each action of the device, easy to understand



Tires: foam-filled tires with good off-road performance



Basket control box: each action of the device can be controlled through the control box to quickly reach the working area, and the control is simple and easy to understand



Standard tracking battery: Reduce 40% of the charge time, raise 50% of the life time