



A Series Electric Stock Picker

with capacities of 1,000lbs

The World of Hangcha
SINCE 1956





HANGCHA

A5.0

8

安全警示
严禁吸烟
小心叉车
入仓车
安全



搬运时注意
（请勿碰撞）

A Series Electric Stock Picker

The truck has a comprehensive safety protection system, excellent ergonomics and advanced control system. Reliable and stable, comfortable and safe, with excellent performance, it supports productive and safe work in busy, confined spaces where workers move short and long distance. It's also proven in environments where small loads are handled in receiving, shipping and put-away, such as retail and manufacturing application.

Innovative/ Safe/ Efficient

Performance

- / With AC traction motor, it has excellent acceleration performance, good climbing performance, low heat generation, no carbon brush and is maintenance-free.
- / CURTIS system provides precise, smooth and efficient control.
- / The CANBUS structure makes the whole truck communication faster and more reliable.





Comfort

- / The truck is designed for smooth elevation and stable reach when lifting and placing loads, reducing operator fatigue.
- / The soft landing and lift top buffering can improve comfort dramatically.
- / The CURTIS multi-function instrument is equipped as standard, which has many functions such as speed selection, wheel display, etc., and can clearly display various information.

Maintenance

- / The AC motor has no carbon brush and is maintenance-free, which greatly saves the cost.
- / The intuitive display offers remaining power, advanced diagnostics and timing for safe, reliable performance.
- / The rear hood can be easily disassembled for easy maintenance of hydraulic unit, electronic control, motor and other parts.

Reliability

- / The frame is made of high-strength steel plate and has a long service life.
- / All wires and cables are reliably protected, greatly improving the reliability of the electrical system.
- / Can provide components such as switches, connectors, instruments, etc. are imported from abroad, with excellent performance and reliable quality.

Safety

- / The low mast provides the operator perfect visibility for safety.
- / Speed control at corner ensures smooth and safe operation.
- / The safety pedals include sensor to ensure the operator has feet properly positioned on the platform. It automatically stops travel and lift/lower functions if foot is removed.
- / The hydraulic system has an emergency manual lowering valve that can be operated at the rear of the vehicle to lower the platform.

Standard Specification

- / AC traction motor
- / CURTIS controller
- / Front load tray
- / Rear load tray (foldable)
- / Automatic speed reduction in corners
- / CURTIS multi-function instrument
- / Maintenance-free battery
- / Battery locking unit
- / Built-in charger
- / Emergency power off switch
- / Safety pedal
- / Tilt switch
- / Left and right guardrail
- / Back cushion
- / Electromagnetic brake

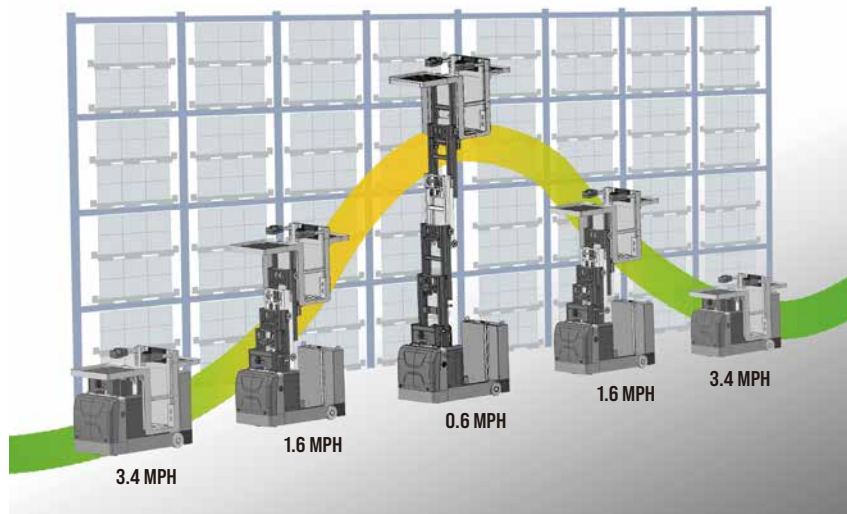

Simultaneous Travel and Lift

With productivity in mind, Hangcha designed the truck to travel and lift simultaneously, so operators can move around a facility while raising or lowering to the appropriate heights in one smooth, seamless operation. The truck reaches a maximum speed of 3.4 mph and adjusts speed based on lift height.



The tilt sensor prevents the vehicle from tipping due to excessive slope and ensures operator safety.



The rear load tray can be folded for working in confined space.



Battery side roll out and built-in charger are equipped as standard, which are convenient for battery replacement and charging operation.



The front and rear large-size trays can greatly improve the efficiency.



The guardrails are equipped with detection switches. The order picker cannot work until the guardrails are put down.

A Series Electric Stock Picker Specification

Distinguishing mark	1.1	Manufacturer		HANGCHA GROUP CO.,LTD.	
		HCFA Model		OPM05	
	1.2	Model		CJD05-AC1-MNA	
	1.3	Drive:electric (battery or mains),diesel,petrol,fuel gas		Electrics	
	1.4	Operator type:hand,pedestrian,standing,seated,order-picker		Order picker	
	1.5	Rated capacity on front tray	Q1(lb/kg)		550/250
		Rated capacity on behind tray	Q2(lb/kg)		220/100
		Rated capacity on standing tray	Q3(lb/kg)		330/150
1.9	Wheelbase	y(in/mm)		45.3/1150	
Weight	2.1	Service weight	lb/kg	3216/1460	
Tyres, chassis	3.1	Tyres: solid rubber, superelastic, pneumatic, polyurethane		Polyurethane/rubber	
	3.2	Tyre size, driving wheels	in/mm	Ø9×3/Ø230×75	
	3.3	Tyre size, loading wheels	in/mm	Ø8×3/Ø204×76	
		Tyre size, caster wheels	in/mm	Ø5×2/Ø125×50	
	3.5	Wheels, number driving, caster/loading (x=drive wheels)		1x,2/2	
Dimensions	4.2	Height,mast lowered	h1(in/mm)	57.8/1468	
	4.4	Lift	h2(in/mm)	145.7/3700	
	4.5	Height, mast extended	h4(in/mm)	203.5/5168	
	4.8	Seat height/standing height	h7(in/mm)	11.8/300	
	4.19	Overall length	l(in/mm)	61.6/1564	
	4.21	Overall width	b1/b2(in/mm)	31.5/31.5,800/800	
	4.31	Ground clearance,laden,below mast	m(in/mm)	1.4/35	
		Initial height of front tray	h2(in/mm)	46/1168	
		Initial height of behind tray	h5(in/mm)	45.5/1156	
		Front tray size	l20×b20(in/mm)	27.6×31.5,700×800	
		Behind tray size	l21×b21(in/mm)	16×31.5,407×800	
		The channel width	Ast(in/mm)	79.7/2025	
	4.35	Turning radius	Wa(in/mm)	52.9/1343	
	Performance Data	5.1	Travel speed,laden/unladen	mph km/h	3.4/3.4 5.5/5.5
5.2		Lift speed,laden/unladen	fpm mm/s	31.5/41.4 160/210	
5.3		Lowering speed,lade/unladen	fpm mm/s	45.3/42.4 230/215	
5.7		Gradeability,laden	%	5	
5.10		Service brake		Electromagnetic	
Electric-engine	6.1	Drive motor rating S2 60 min	hp/kw	2/1.5	
	6.2	Lift motor rating at S3 15 %	hp/kw	3/2.2	
	6.4	Battery voltage/nominal capacity K3	V/Ah	24/200	
	6.5	Battery weight	lb/kg	430/195	
Addition data	10.7	Sound pressure level at the driver's seat	dB(A)	69	
Others	11.1	Type of drive control		Curtis AC	

Optional :

1、lift h3=116.5in/2960mm

2、battery capacity 24V/300Ah,lead-acid

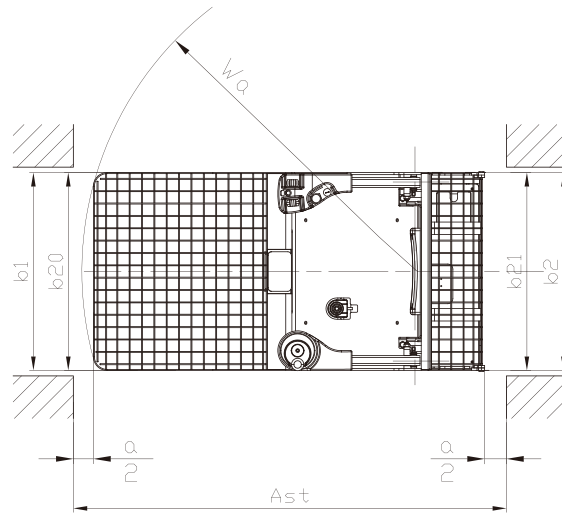
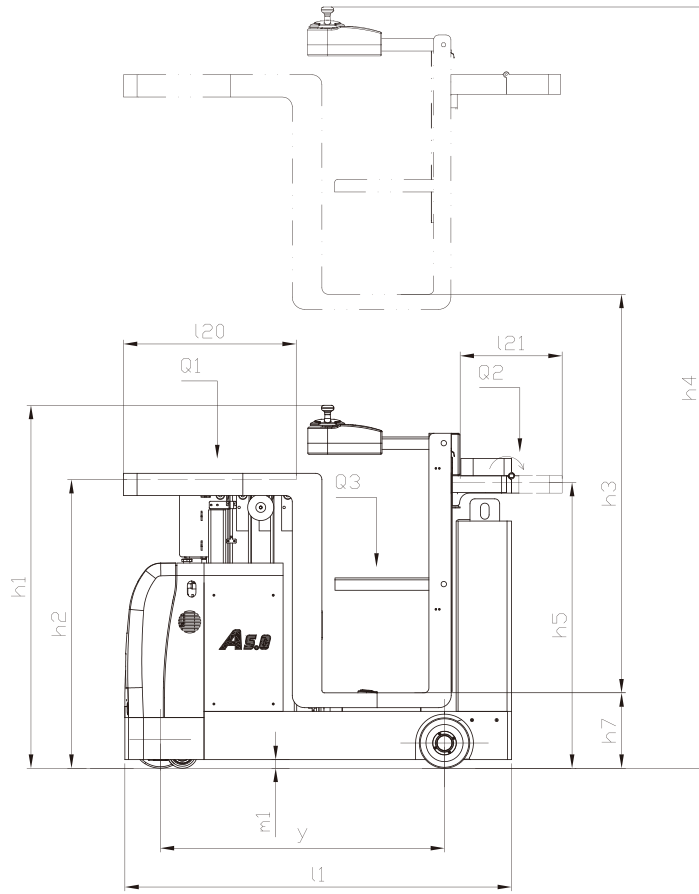

CAPACITY
KG (LBS)

150 (330)
 250 (550) 100 (220)

One Operator-No Passengers

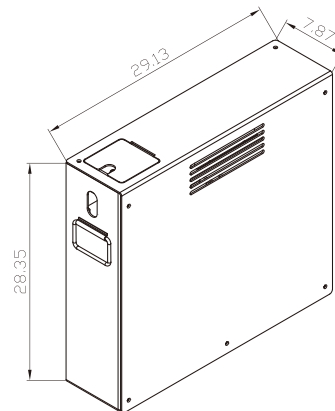



HC FORKLIFT AMERICA CORPORATION

Company address:
10405-A Granite Street Charlotte,
NC 28273

Toll Free: 888-652-8395
Phone: 980-888-8335
Fax: 980-888-8336

america@hcforklift.com
www.hcforkliftamerica.com



Follow us on
Facebook



Follow us on
YouTube



Follow us on
WeChat

HANGCHA GROUP CO., LTD. reserves the right to make any changes without notice concerning colors, equipment, or specifications detailed in this brochure, or to discontinue individual models. The colors of trucks, delivered may differ slightly from those in brochures.